

Journal Article

GUI Design Exploration Software for Microwave Antennas

Liu, B., Irvine, A., Akinsolu, M., Arabi, O., Ali, N., Grout, V.

This article is published by Elsevier. The definitive version of this article is available at:

<http://www.sciencedirect.com/science/article/pii/S2288430017300088>

Recommended citation:

Liu, B., Irvine, A., Akinsolu, M., Arabi, O., Ali, N., Grout, V. (2017), 'GUI Design Exploration Software for Microwave Antennas', Journal of Computational Design and Engineering, Elsevier. Available online 13/04/17. doi: 10.1016/j.jcde.2017.04.001.

GUI Design Exploration Software for Microwave Antennas

Bo Liu^a, Alexander Irvine^b, Mobayode O. Akinsolu^b, Omer Arabi^b, Vic Grout^b, Nazar Ali^c

^a*School of Electrical, Electronic and System Engineering, The University of Birmingham and Department of Computing, Wrexham Glyndwr University, U.K.*

^b*Department of Computing, Wrexham Glyndwr University, U.K.*

^c*Department of Electronic and Electrical Engineering, Khalifa University, UAE.*

Abstract

Optimizers in commercial electromagnetic (EM) simulation software packages are the main tools for performing antenna design exploration today. However, these general purpose optimizers are facing challenges in optimization efficiency, supported optimization types and usability for antenna experts without deep knowledge on optimization. Aiming to fill the gaps, a new antenna design exploration tool, called Antenna Design Explorer (ADE), is presented in this paper. The key features are: (1) State-of-the-art antenna design exploration methods are selected and embedded, addressing efficient antenna optimization (critical but unable to be solved by existing tools) and multiobjective antenna optimization (not available in most existing tools); (2) Human-computer interaction for the targeted problem is studied, addressing various usability issues for antenna design engineers, such as automatic algorithmic parameter setting and interactive stopping criteria; (3) Compatibility with existing tools is studied and ADE is able to co-work with existing EM simulators and optimizers, combining advantages. A case study verifies the advantages of ADE.

Keywords: Antenna design optimization, Antenna synthesis, Surrogate model assisted evolutionary algorithm, Multiobjective optimization, Software tool

Email addresses: b.liu.3@bham.ac.uk, b.liu@glyndwr.ac.uk (Bo Liu), a.irvine@glyndwr.ac.uk (Alexander Irvine), m.o.akinsolu@ieee.org (Mobayode O. Akinsolu), arikabi@ieee.org (Omer Arabi), v.grout@glyndwr.ac.uk (Vic Grout), ntali@kustar.ac.ae (Nazar Ali)

1. Introduction

An antenna is an essential device in satellites, automobiles and many electrical machines. In recent years, design exploration or design optimization has replaced the traditional trial and error method and has become a standard step
5 in the microwave antenna design process. Antenna design exploration aims to obtain optimal geometrical design parameters optimizing (a) design objective(s) and/or satisfying design specifications based on a given antenna structure. Over the last decade, a number of research works have been carried out on this topic, providing useful results. The proposed methods mainly include employing tra-
10 ditional derivative-based and derivative free methods [1], as well as employing evolutionary algorithms [2].

Due to the importance of design exploration in electromagnetic (EM) device design flow, these research products are transferred to commercial software tools rapidly. CST Microwave Studio [3], Ansoft HFSS [4], ADS-Momentum
15 [5], Altair-FEKO [6], Sonnet Suites [7], etc are major tools for antenna design engineers to perform design exploration. MathWorks has also provided an antenna toolbox since 2015 using MATLAB optimizers to perform antenna design exploration. Although from different computer-aided design (CAD) soft-
20 ware vendors, most of their optimizers follow the same idea: embedding various kinds of general purpose optimization methods and connecting them with their EM simulators.

In terms of optimization methods employed, CST Microwave Studio, Ansoft HFSS, ADS-Momentum, Altair-FEKO and the MATLAB antenna toolbox include both local optimization methods and global optimization methods. For
25 local optimization, common methods are the Quasi-Newton method, the Sequential Quadratic Programming method, the Trust-region method and the Pattern Search method. For global optimization, the common methods are Genetic Algorithms (GAs) and the Particle Swarm Optimization (PSO) method. In addition, CST Microwave Studio introduces the Covariance Matrix Adapta-

30 tion Evolution Strategy, which is a state-of-the-art global optimization method. In terms of optimization type, Sonnet supports constraint satisfaction, i.e., aiming to satisfy several design specifications using weighted sum. CST Microwave Studio, Ansoft HFSS, Altair-FEKO and ADS-Momentum support constraint satisfaction, goal optimization and constrained optimization.

35 Although the available antenna design exploration tools make significant contributions for antenna design engineers, the following two challenges remain: Arguably, the most critical challenge is the optimization efficiency. The success of local optimization methods relies on a good initial design. However, unlike some other EM devices (e.g., filters), there is no routine method to get a
40 good initial design for an antenna. Hence, many engineers incline to use global optimization methods. Although a good initial design is not needed and the optimization ability is much higher, global optimization methods often need a large number of EM simulations to get the optimum. Considering that each full wave EM simulation is often computationally expensive, the whole optimization
45 process may cost weeks to months. [To the best of our knowledge, no available tool is able to address this challenge till now.](#)

Secondly, a common problem is that many antenna design engineers do not have a deep knowledge of optimization, but this is considered less in available tools, decreasing the usability. For example, there are geometric constraints to
50 many antenna structures, which are naturally handled without performing computationally expensive EM simulations from the view of experts on optimization; but many available tools often do not support this pre-processing. For another example, algorithmic parameters, such as the penalty coefficients for constraint satisfaction/optimization, affect the result significantly, but setting them is left
55 to antenna engineers themselves in the available tools.

To address the above challenges, a new tool, called Antenna Design Explorer (ADE), is presented in this paper. ADE does not aim to repeat functions of existing commercial tools; [therefore, optimization methods in available tools are not employed.](#) ADE also does not aim to develop software tools for a specific
60 kind of antenna as some pioneer academic research work e.g., [8]. Instead, ADE

intends to become a tool considering the handling of key challenges on functionality, generality and usability for common antenna engineers. In particular, ADE aims to provide the following features:

- Support efficient design exploration: A state-of-the-art efficient antenna design exploration method, [Surrogate Model-Assisted Differential Evolution for Antenna Synthesis](#) (SADEA) [9], is embedded to address efficient single objective antenna design exploration;
- Support multiobjective design exploration: A state-of-the-art multiobjective optimization method, [Multiobjective Evolutionary Algorithm Based on Decomposition-Differential Evolution Operators](#) (MOEA/D-DE) [10], is included to support multiobjective antenna design optimization, which is attracting considerable attention in recent years;
- Support antenna design engineers without sufficient expertise in optimization: The usability concerns for the targeted users are studied and included in the tool, including automatic algorithmic parameter setting, efficient handling of geometrical constraints, interactive stopping criteria and graphics user interface (GUI) connecting CST Microwave Studio, etc.
- Support co-work with existing EM simulators and optimizers: Compatibility with existing tools is considered and designed in ADE, so as to combine their advantages. A new design exploration routine is proposed based on the co-working of ADE and existing optimizers.

In addition, comprehensive supporting materials are provided for ADE 1.0, including a user's guide, templates for constructing objective functions and constraints, examples and tutorial videos. The materials can be downloaded from <http://ade.cadescenter.com>.

The remainder of this paper is organized as follows. Section 2 provides the problem formulation. Section 3 introduces ADE, including the work flow, optimization methods selection, usability study, supporting materials and software

design. A case study is provided in Section 4. Section 5 provides conclusions
 90 and future work.

2. Problem Formulation

ADE supports four types of optimization: constraint satisfaction, goal optimization, single objective constrained optimization and multiobjective optimization, which are listed as follows.

constraint satisfaction

$$\begin{aligned} & \text{minimize} && \sum_{i=1}^k w_i \times \max(g_i(x), 0) \\ & \text{s.t.} && x \in [a, b]^d. \end{aligned} \tag{1}$$

95 where x is the vector of design variables; d is the dimension of x ; $[a, b]^d$ are the search ranges of the design variable x ; $g_i(x) \leq 0$ is the i^{th} specification ($i = 1, 2, \dots, k$) and w_i is the weight of the i^{th} specification.

goal optimization

$$\begin{aligned} & \text{minimize} && f(x) \\ & \text{s.t.} && x \in [a, b]^d. \end{aligned} \tag{2}$$

where $f(x)$ is the optimization goal (objective function).

single-objective constrained optimization

$$\begin{aligned} & \text{minimize} && f(x) \\ & \text{s.t.} && g_i(x) \leq 0, i = 1, 2, \dots, k. \\ & && x \in [a, b]^d. \end{aligned} \tag{3}$$

Single-objective constrained optimization is very popular in real-world an-
 100 tenna design exploration. Often, a candidate design with a minimum $f(x)$ value among those satisfying the $g_i(x) \leq 0$ constraints is the optimal solution. Sometimes, candidate designs which slightly violate the $g_i(x) \leq 0$ constraints but with a much better $f(x)$ values are preferred by the designer.

Multi-objective optimization

$$\begin{aligned} & \text{minimize} && \{f_1(x), f_2(x), \dots, f_m(x)\} \\ & \text{s.t.} && x \in [a, b]^d. \end{aligned} \tag{4}$$

Multiobjective optimization produces a number of well representative optimal trade-off candidate solutions for the antenna engineer to select. Let x and x' be two solutions to (4) where $m = 2$. x is said to dominate x' if and only if $f_1(x) \leq f_1(x')$, $f_2(x) \leq f_2(x')$, and at least one of these two inequalities is strict. A solution x^* is Pareto-optimal if there is no other solution that dominates it. The set of all the Pareto-optimal solutions is called the Pareto set and the image of Pareto set in the objective space (i.e., $f_1 - f_2$ space) is the Pareto front.

As was described in Section 1, Sonnet Suites addresses constraint satisfaction (eqn. (1)), which is essential in antenna design exploration. However, in many cases, the setting of specifications is not obvious. For example, $\max|S_{11}| \leq -20dB$ is a widely used design specification, but it may not be achievable for some antenna structures, while for others, better $\max|S_{11}|$ can be achieved. Thus, $\max|S_{11}|$ is more appropriate to be set as a design objective. Hence, CST Microwave Studio, Ansoft HFSS, ADS-Momentum and MATLAB antenna toolbox support goal optimization (eqn. (2)) and single objective constrained optimization (eqn. (3)). Few available tools support multiobjective optimization (eqn. (4)), which provides a set of approximated Pareto optimal designs. When the computational cost is affordable (e.g., high-performance computing, low-fidelity EM simulation, analytical formula), multiobjective optimization is very useful in understanding the antenna, which receives considerable attention from researchers, e.g., [11, 12].

3. The ADE Software

3.1. Architecture of ADE

ADE is a GUI software tool programmed in MATLAB. The reason for choosing MATLAB language is that MATLAB is a common working environment for both antenna design engineers and optimization researchers. In particular, (1) MATLAB code for many modern optimization algorithms is available, which improves the efficiency of development and update of ADE software tools; (2)

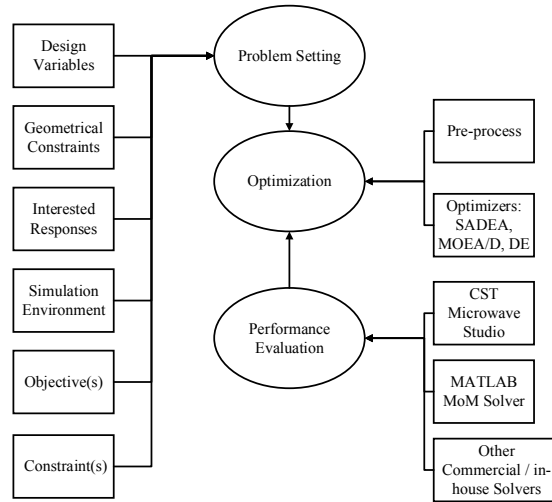

Figure 1: The architecture of ADE

The MATLAB antenna toolbox and optimization toolbox can be seamlessly linked with ADE; (3) Almost all antenna engineers are familiar with MATLAB
 135 because MATLAB and Simulink are their essential tools for communication system modelling.

The architecture of ADE is shown in Fig. 1. The three main modules are the performance evaluation module, the problem setting module and the optimization module. The performance evaluation module will be introduced in
 140 Section 3.2, the optimization algorithm selection will be introduced in Section 3.3 and the problem setting module and the pre-processing functions in the optimization module will be introduced in the workflow (Section 3.4).

3.2. Performance Evaluation Module

In antenna design exploration, the performance of each candidate design
 145 generated in optimization needs to be obtained by an analyzer, often, based on numerical simulations. ADE does not provide its own numerical analyzer, but instead invokes existing EM simulation software tools. This does not restrict the applicability of ADE but rather broadens it. The reason is that almost all

antenna engineers has at least one commercial EM simulation software tool and
150 their reliability is trusted. Among various commercial EM simulation software
tools, arguably, CST Microwave Studio and Ansoft HFSS are the most widely
used for antenna simulation.

In the current (1.0) version of ADE, two kinds of links to external simulators
are provided. The first one is a seamless link with CST Microwave Studio. Using
155 this link, the user only needs to provide the prepared CST simulation model as
they do in manual antenna design and several straightforward settings (e.g., the
installation path, the solver type used) through the GUI. The second one is a
MATLAB terminal. The user's input will be saved as an m-file. By using this
terminal, invoking a simulation model based on the MATLAB antenna toolbox
160 or analytical formula is straightforward. Other EM simulation tool users or in-
house numerical analysis code users can use this terminal to get access to the
optimizers of ADE.

3.3. Selection of Optimization Methods

The optimizer is the key in ADE 1.0. Recall that ADE is designed for
165 antenna design engineers without a deep knowledge of optimization. We, there-
fore, refrain from providing a number of optimization algorithms to avoid users
being confused as to which one to choose. Three optimization methods are
selected for different kinds of problems encountered in antenna design explo-
ration. Ranked by importance, they are Surrogate Model Assisted Differential
170 Evolution for Antenna Synthesis (SADEA) [9], Multiobjective Evolutionary Al-
gorithm by Decomposition / Differential Evolution Operators (MOEA/D-DE)
[10] and Differential Evolution (DE) [13].

As was introduced in Section 1, local optimization methods require a good
starting point, which is often not available for practical antenna design (Even in
175 some cases when local optimization methods can be used, they can be accessed
from existing commercial tools.) Global optimization methods are shown to
be very effective, but they often cost too much time (e.g., months) for EM
simulation-embedded antenna optimization. SADEA is used to address this

problem. Experiments on real-world antennas show that the SADEA method
180 obtains a 4-10 times speed improvement compared to standard DE and PSO
methods, while getting comparable results. This indicates that by using ADE,
the design quality is not sacrificed while decreasing 1 or 2 month optimization
time to 1 week. SADEA supports constrained satisfaction (eqn. (1)), goal
optimization (eqn. (2)) and single-objective constrained optimization (eqn. (3)).

185 Multiobjective antenna optimization has been attracting much attention in
recent years (especially when using a computationally relatively cheap low-
fidelity simulation model) but existing tools seldom support it. To the best
of our knowledge, one way to perform multiobjective antenna optimization is
co-use of the MATLAB optimization toolbox and MATLAB antenna toolbox.
190 A variant of NSGA-II [14] is embedded in the MATLAB optimization toolbox,
which is more than 15 years old. MOEA/D [15] is a more recent state-of-the-art
method. MOEA/D and its variant MOEA/D-DE (a popular variant) have more
than 2000 citations to date. Pioneer researchers have employed an MOEA/D
variant to multiobjective antenna design exploration and showed success [11].
195 Because of this, MOEA/D-DE is embedded in ADE to support multiobjective
antenna optimization (eqn. (4)).

DE is a standard evolutionary algorithm for global optimization and is widely
used in antenna design exploration research [16, 17]. However, it is seldom
included in available tools. To complement the existing tools, it is included
200 in ADE. It has to be recognized that for some particular antennas, analytical
formulas, equivalent circuits or superposition models can be obtained, which is
computationally very cheap (e.g, a few seconds or less). In such cases, using
DE may not be inefficient compared to SADEA, since no time is expended on
surrogate modelling. Including a DE optimizer is useful for research involving
205 the above low-cost evaluation models, so as to complement GAs and PSO in
existing tools.

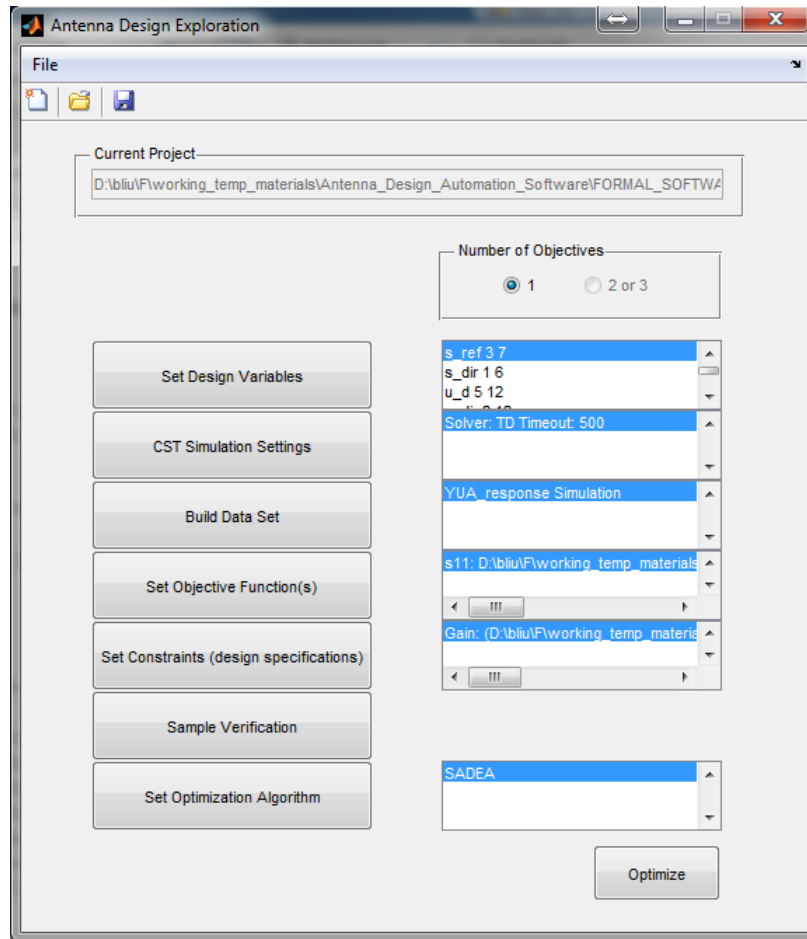

Figure 2: The starting window of ADE

3.4. Workflow of ADE

The workflow of ADE is as follows, which is also shown in the starting GUI window (Fig. 2).

210 1. Set design variables:

This step sets the design variables that will be optimized and their ranges.

2. Set geometrical constraints (if any):

Geometrical constraints exist in many antennas, describing the restrictions between the design variables. For example, L_1 should be less than a half of L_2 , where L_1 and L_2 are design variables. Handling them does not need computationally expensive EM simulations. ADE provides two kinds of methods: smart design parameters and explicit geometrical constraints setting.

3. CST simulation settings:

When the designer uses CST Microwave Studio as the performance evaluation method, this step collects the CST installation path, solver type and simulation time estimation for using the seamless link with CST.

4. Build data set:

This step defines the responses that the user wants to be included in the optimization problem, which will be involved in the objective function(s) or the constraint(s) afterwards. For CST Microwave Studio users, a simulation is carried out and all the responses are then displayed for the user to select. For non-CST users, a MATLAB function terminal is opened for inputting code or invoking other EM tools.

5. Set objective(s):

The objective function(s) is/are set based on the responses given in Step 4. An m-file template is automatically generated with responses as the inputs. The user can then define the objective function(s) using the given responses.

6. Set constraints(s):

The constraint(s) is/are set based on the responses given in Step 4. An m-file template is also automatically generated as in Step 5.

7. Sample verification:

This step has two functions. The user can validate the objective function
240 value(s) and constraint function value(s) for a single design, making sure
that the optimization problem is correctly set. Bearing in mind that the
optimization is often not cheap, it is worth performing this verification.
The user can also generate a certain number of samples to observe the
design landscape.

245 **8. Select optimization algorithms and set parameters:**

The user can select one of the three embedded optimizers (Section 3.3) or use a
custom algorithm to perform antenna design exploration. When using the
embedded optimizers, most algorithm parameters can be automatically
calculated based on problem settings and the initial samples/responses if
250 the user chooses “auto”. **If selecting the “custom algorithm” option, the ob-
jective function and constraints with embedded simulations are displayed
as normal MATLAB functions, which can be used by any user-defined
algorithm.**

9. Design exploration:

255 This step performs optimization based on the user’s selections and provides
the optimized antenna design parameters.

3.5. Usability Study

The alpha-version of ADE is tested by antenna design engineers without
a deep knowledge of optimization, who are the targeted users. Together with
260 antenna engineers, the usability is studied and improved in various aspects. In
the following, a few major ones are described.

Antenna engineers are used to evaluating candidate designs by observing
the response curves. When asking antenna engineers to write objective and
constraint functions considering various inputs (e.g., various performances, in-
265 terested frequency range, whole frequency range, output data format, etc.), the
usability becomes low. A solution is to make a separate GUI for each possi-
ble antenna response (e.g., S_{11} , gain), in which, every related choice is covered

(e.g., output in dB/magnitude/complex). However, the software may become complex and less flexible to handle various kinds of problems.

270 To address this problem, the following usability improvement method is proposed: (1) The objective and constraint functions settings are broken down to simulation settings, response settings using the set simulation environment and objective and constraint functions setting using the set responses. (2) A GUI is designed to guide the user in selecting signal files from the simulation
275 results (Fig. 3) and the data is then displayed to the user (by saving them to mat files, which can be viewed from the MATLAB Workspace) for easy handling when setting objective and constraint functions. A video is designed to show the details, and the interpretation of the signal files is provided in the user's guide. Experiments show that this largely relieves the difficulty of the users and
280 is general to all responses, avoiding an ad-hoc GUI for each antenna response. (3) m-files with a template and instructions are used in all the function settings, providing both hints (e.g., interpolation) and flexibility for the user (e.g., setting fabrication tolerance). Often, the user only needs to slightly revise the template to fit in his/her own problems.

285 As was described in Section 1, many antennas have geometrical constraints. Unlike response constraints, for which simulation must be used, they can be handled before simulation. In ADE, for a simple geometrical constraint, smart design parameter setting can be used, making the geometrical constraint naturally satisfied. An example is shown in Section 4. This is also available in some
290 existing tools. For complex geometrical constraints, using the Geometrical Constraints Window, ADE revises the geometrically infeasible candidate designs to the nearest feasible ones before EM simulations. A number of EM simulations can, therefore, be saved compared to using general purpose optimizers in existing tools, which treat them the same as response constraints.

295 Setting algorithmic parameters (e.g., population size or weights of the constraints) by antenna engineers themselves is a serious usability issue for many existing EM optimizers. Some of these parameters do largely influence the algorithm performance, but many antenna engineers find it difficult to make the

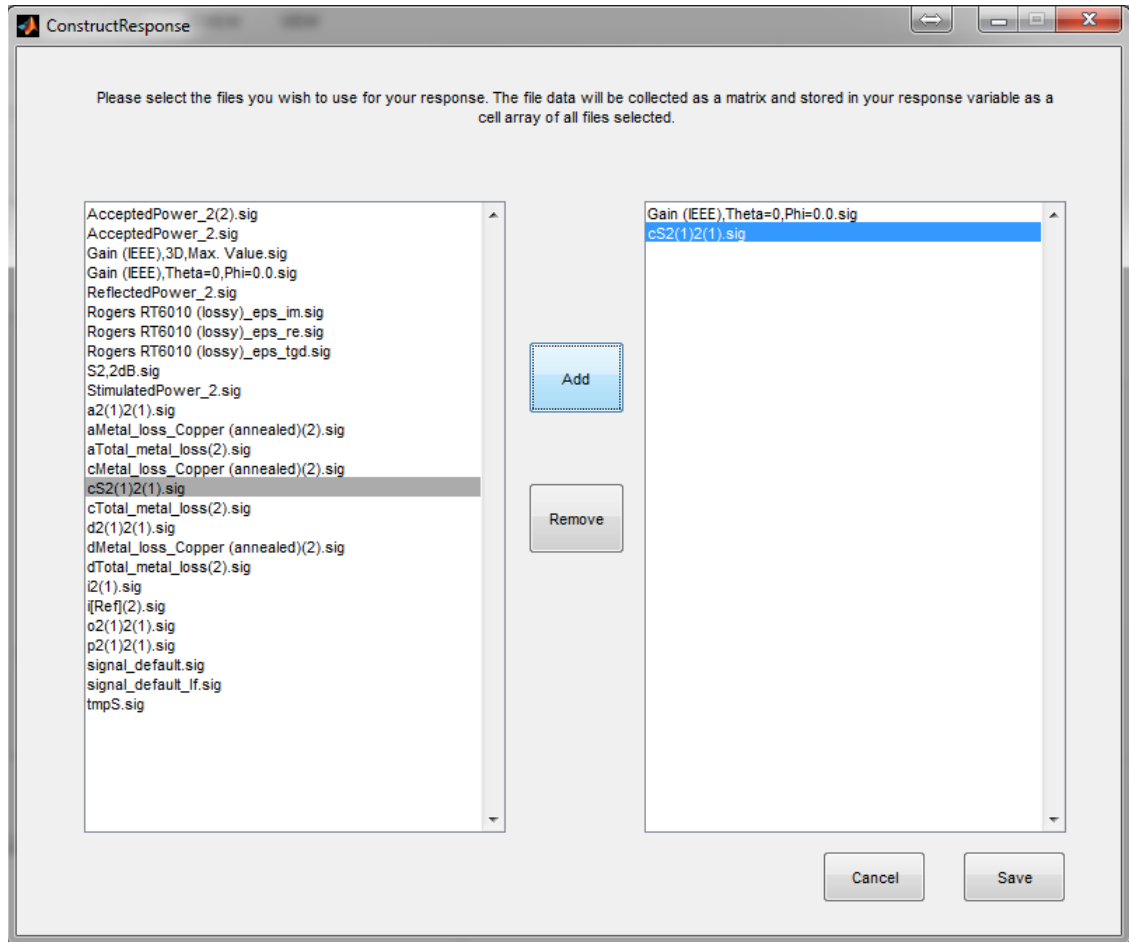

Figure 3: GUI for selecting responses

(most) appropriate setting and the default setting is, in many cases, not optimal. In ADE, with the exception of one parameter (the clear rule to set it is provided in the user’s guide) and the number of evaluations (discussed later), all other algorithmic parameters can be adaptively calculated by a set of rules and are automatically set. The rules are obtained by analyzing optimization results of various kinds of antennas (e.g., dielectric resonator antenna, microstrip antenna, Yagi-Uda antenna, ultra wideband antenna, on-chip antenna, antenna arrays, etc).

Stopping criteria (i.e., the number of evaluations) is an important usability issue because the design exploration is often computationally expensive. The user would like to stop the optimizer at the correct time in order to avoid either a suboptimal result or long but redundant optimization time. However, the necessary number of evaluations is problem dependent and most existing tools only show the current best design to the user. In ADE, not only can the user view the trend of objective function values or the Pareto front improvements in the optimization process at any time, but also the standard deviation of the current population is shown to the user, which is a useful reference to predict the extent of further improvement (the use of it is included in the user’s guide), so as to decide the number of further evaluations. As with existing tools, the optimization can stop at any time with results saved, and any further evaluations can be amended.

In addition, some widgets, (e.g., the mouse hover, the graying out of inapplicable entries) are used in the GUI to further improve the usability, which will not be described in detail here.

3.6. Supporting Materials

Comprehensive supporting materials are provided for ADE, including tutorial videos, a user’s guide and m-file templates (available at <http://ade.cadescenter.com>). The purpose of the “step-by-step” tutorial videos is to elaborate the details of using ADE, which is more effective than document-based tutorials. Several real-world antenna examples with different demands on the design exploration tool

are selected, covering single/multiple objective optimization, handling response
330 constraints, smart design parameters, explicit geometrical constraints, using
CST simulation, using analytical function evaluation, using the three embedded
optimizers and co-work with other tools.

The user’s guide concentrates on providing comprehensive support for non-
straightforward issues when using ADE besides introducing the software. For
335 example, interpretation of CST response signals for easy checking, interpolation
for signals and observing and interpretation of optimization results. In addition,
the basic concepts of optimization are introduced in the user’s guide with
antenna examples for beginners. Common mistakes are also summarized.

The purpose of the template m-files is to allow the user to easily set their
340 problems while maintaining flexibility. Templates for objective and constraint
functions (with different output formats) and interpolations are provided. The
user can slightly revise the templates to fit with their own problems or can write
new files with the provided hints if necessary.

3.7. *Compatibility with Other Tools*

345 As was mentioned in Section 1, an important aim of ADE is to co-work with
existing tools to merge the advantages, which mainly includes co-work with
available simulators and optimizers. The former topic has been discussed in
Section 3.2. The latter is opened by the “Custom Algorithm” terminal (Step
8 of the workflow). By using this terminal, the objective function(s) and con-
350 straint(s) built (including connections with CST Microwave Studio or other
tools) are displayed as black boxes, which can be used by other optimization
algorithms or other kinds of algorithms (e.g., Design of Experiments). This
allows ADE to be extended by optimization experts or antenna engineers with
available optimization code.

355 In particular, an efficient multi-fidelity antenna design exploration method is
proposed by using ADE and available optimization tools. For some (e.g., satel-
lite) antennas, high-fidelity EM simulation is computationally very expensive.
A possible way to address this problem is multi-fidelity design exploration [18].

A low-fidelity model is firstly used with the SADEA optimizer. Consequently,
360 combining the fast optimization of SADEA and the reasonable cost simulation
of a low-fidelity EM model, an optimal result with low-fidelity simulation can
be obtained efficiently. Secondly, the optimal design obtained is used as the ini-
tial design for local optimization using high-fidelity EM simulations. Although
ADE does not include a local optimizer, local optimizers from available tools
365 can be employed. For example, CST Microwave studio can be used straight-
forwardly. In addition, the powerful MATLAB optimization toolbox can be
employed from the Custom Algorithm terminal. A case study implementing
multi-fidelity design exploration is described in the next Section.

4. Case Study

370 In this section, use of ADE is illustrated by a case study: design exploration
of a dielectric resonator (DR) antenna. The SADEA optimizer is used for the
low-fidelity EM model-based global design exploration and the Nelder-Mead
(NM) Simplex method [19] from the MATLAB optimization toolbox is used to
perform local design exploration.

375 The antenna structure is shown in Fig. 4 [20]. The rectangular DR is
excited at the $TE_{\delta 11}$ mode with a 50Ω microstrip through a slot made in the
metal ground plane. The substrate is 0.5mm thick RO4003C of infinite lateral
extends. Metallization of the ground and the microstrip trace (the width w_0
of 1.15mm) is with 0.05mm thick copper. DR relative permittivity and loss
380 tangent are 10 and 0.0001, respectively.

The design task is to adjust dimensions of the DR brick (ax , ay and az),
the slot dimensions (us and ws), the length of the microstrip slab (ys) and
location of the DR relative the slot (ac), so that the bandwidth of the DR
antenna is to be centred at 5.5GHz and the value of the fractional impedance
bandwidth at -10dB level is to be at least 8%. Also the back radiation (down
the substrate) should be kept as low as possible. Design constraints imposed
on the DR antenna radiation are the following: (1) the realized gain is to be

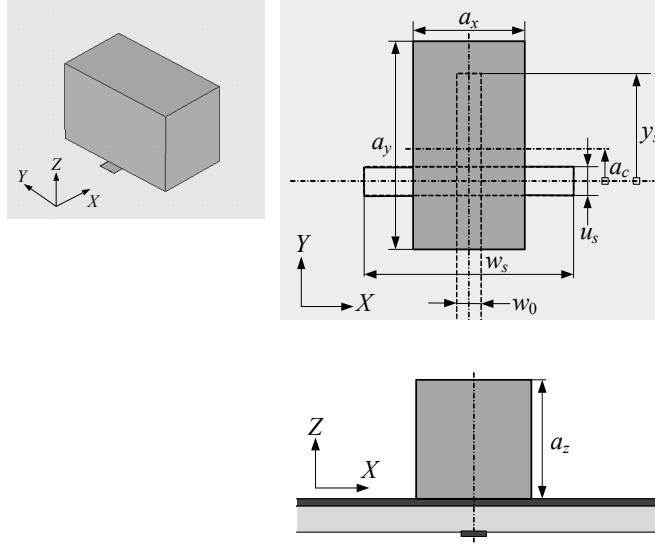

Figure 4: Single brick DR antenna: (a) 3D view, layout top (b) and front (c) views

Table 1: Ranges of the design variables (all sizes in mm) for antenna design exploration

<i>Variables</i>	ax	ay	az	ac	us	ws	ys
Lower bound	6	12	6	6	0.5	4	2
Upper bound	10	16	10	8	4	12	12

not less than 3dB for the zero zenith angle, and (2) the realized gain of back radiation is to be less than -10dB. Both gain constraints are to be imposed over the impedance bandwidth achieved. The design variables are ax , ay , az , ac , us , ws and ys . Their ranges are in Table 1. The objective function is as follows with the frequency range of 5.28GHz to 5.72GHz:

$$\text{minimize } \max |S_{11}| \quad (5)$$

To illustrate both the fundamental use of ADE and multi-fidelity design exploration by ADE, two fidelities are used. Both EM modules are constructed with CST Microwave Studio. The number of mesh cells used for the low-fidelity

model is around 22,000 and, for the high-fidelity model, around 615,000. The
385 simulation time of the low-fidelity model and the high-fidelity model are about
35s and 6 minutes, respectively, using a PC with an Intel Xeon 1.9GHz CPU
and 24GB RAM.

The setting and optimization process of this case study are shown by a
tutorial video (<http://www.youtube.com/watch?v=uCew4pgaVIE>). Note that
390 there is a geometrical constraint: ac should be less than $0.5 \times ay$. In ADE,
the Smart Parameter function can be used to handle this simple constraint. In
this example, a variable r with a range of $[0, 0.5]$ is introduced and $r \times ay$ is
used to replace ac . Hence, this constraint is naturally satisfied. More complex
geometrical constraints have to be included using the Geometrical Constraint
395 function, whose usage is shown by a broadband microstrip antenna video and
the user's guide.

The tutorial video shows that the trend of objective function value in the op-
timization process and the standard deviation of the current population. When
observing it at 400 simulations, it can be seen that based on the standard devi-
400 ation, there is much potential for the objective function to be further improved
(the details of analyzing the standard deviation is introduced in the user's guide).
Hence, another 200 simulations are added. This process repeats for 1000 simu-
lations, at which point the potential improvement is relatively small.

The low-fidelity model-based design exploration after 1000 simulations ob-
405 tains a result of $\min(\max|S_{11}|) = -23.6dB$, in around 10 hours. It should be
noticed that, when using the DE optimizer in ADE, and GA or PSO optimizers
in existing tools, similar results can also be obtained, but the time consumption
is much longer. For example, around 150 hours are cost with the CST Mi-
crowave Studio PSO optimizer. Therefore, using the SADEA optimizer for EM
410 simulation-based global design exploration is highly recommended in this multi-
fidelity design exploration flow. The $\min(\max|S_{11}|)$ value of the optimal design
obtained but with a high-fidelity EM simulation model, is -13.2dB. Then, the
obtained optimal design is used as the starting point of the NM simplex method.
Through the Custom Algorithm terminal, the `fminsearch` function is employed

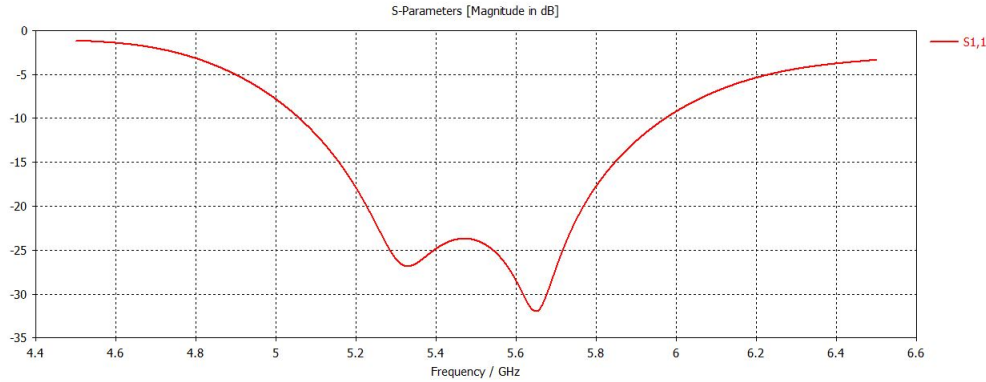

Figure 5: Response of the solution obtained by ADE 1.0

415 from the MATLAB optimization toolbox.

After 51 high-fidelity EM simulations (based on the EM model of CST Microwave Studio), the optimal result is $S_{11} = -24.2dB$ based on the high-fidelity model, taking around 5 hours. The final response is shown in Fig. 5. By using ADE, the total design exploration time is 15 hours.

420 5. Conclusions

In this paper, the Antenna Design Explorer (ADE) software tool has been presented. With ADE, antenna design engineers, without sufficient expertise of optimization, can perform efficient antenna design exploration and multiobjective antenna design exploration straightforwardly. The main advantages include
 425 important optimizers that are not available in existing tools as well as an intensive usability study fully considering the user's background. In addition, the compatibility of ADE makes it able to co-work with existing EM simulators and optimizers, combining advantages. Carefully designed supporting materials are available at <http://ade.cadescenter.com>, including user's guide, templates for
 430 constructing objective functions and constraints, examples and tutorial videos. For the next (2.0) version, future works include: (1) building seamless links to various widely used EM simulation tools, (2) including data mining-assisted multi-fidelity antenna design optimization techniques [21] and (3) comparing

and embedding other state-of-the-art multiobjective antenna design exploration
435 method(s).

Acknowledgement

The authors would like to thank Prof. Slawomir Koziel, Reykjavik University, for valuable test examples and help.

References

- 440 [1] J. Bandler, Q. Cheng, S. Dakroury, A. Mohamed, M. Bakr, K. Madsen, J. Sondergaard, Space mapping: the state of the art, *IEEE Transactions on Microwave Theory and Techniques* 52 (1) (2004) 337–361.
- [2] A. Hoorfar, Evolutionary programming in electromagnetic optimization: a review, *IEEE Transactions on Antennas and Propagation* 55 (3) (2007)
445 523–537.
- [3] CST, Studio-workflow and solver overview, CST-Computer Simulation Technology AG.
- [4] Ansoft, Hfss online help, Ansoft Inc.
- [5] Agilent, Agilent eesof eda: Advanced design system, Agilent Technologies
450 Inc.
- [6] Altair, Feko user manual, Altair Engineering Inc.
- [7] Sonnet, High frequency electromagnetic software sonnet suites: User’s guide, Sonnet Software Inc.
- [8] S. Zhao, C. Fumeaux, T. Fickenscher, Matnec: An in-house developed
455 tool for electromagnetic simulation and evolutionary optimization of wire antennas, in: *Numerical Electromagnetic Modeling and Optimization for RF, Microwave, and Terahertz Applications (NEMO)*, 2014 International Conference on, IEEE, 2014, pp. 1–4.

- [9] B. Liu, H. Aliakbarian, Z. Ma, G. A. Vandenbosch, G. Gielen, P. Excell,
460 An efficient method for antenna design optimization based on evolution-
ary computation and machine learning techniques, *IEEE Transactions on
Antennas and Propagation* 62 (1) (2014) 7–18.
- [10] H. Li, Q. Zhang, Multiobjective optimization problems with complicated
pareto sets, moea/d and nsga-ii, *IEEE Transactions on Evolutionary Com-*
465 *putation* 13 (2) (2009) 284–302.
- [11] R. d. Carvalho, R. R. Saldanha, B. Gomes, A. C. Lisboa, A. Martins, A
multi-objective evolutionary algorithm based on decomposition for optimal
design of yagi-uda antennas, *IEEE Transactions on Magnetics* 48 (2) (2012)
803–806.
- 470 [12] S. Koziel, A. Bekasiewicz, Fast multiobjective optimization of narrowband
antennas using rsa models and design space reduction, *IEEE Antennas and
Wireless Propagation Letters* 14 (2015) 450–453.
- [13] K. Price, R. Storn, J. Lampinen, *Differential evolution: a practical ap-
proach to global optimization*, Springer Verlag, 2005.
- 475 [14] K. Deb, *Multi-objective optimization using evolutionary algorithms*,
Vol. 16, John Wiley & Sons, 2001.
- [15] Q. Zhang, H. Li, Moea/d: A multiobjective evolutionary algorithm based
on decomposition, *IEEE Transactions on evolutionary computation* 11 (6)
(2007) 712–731.
- 480 [16] L. Zhang, Z. Cui, Y.-C. Jiao, F.-S. Zhang, Broadband patch antenna design
using differential evolution algorithm, *Microwave and Optical Technology
Letters* 51 (7) (2009) 1692–1695.
- [17] M. A. Panduro, C. A. Brizuela, L. I. Balderas, D. A. Acosta, A comparison
of genetic algorithms, particle swarm optimization and the differential evo-
485 *lution method for the design of scannable circular antenna arrays*, *Progress
In Electromagnetics Research B* 13 (2009) 171–186.

- [18] B. Liu, S. Koziel, Q. Zhang, A multi-fidelity surrogate-model-assisted evolutionary algorithm for computationally expensive optimization problems, *Journal of Computational Science* 12 (2016) 28–37.
- 490 [19] J. A. Nelder, R. Mead, A simplex method for function minimization, *The Computer Journal* 7 (4) (1965) 308–313.
- [20] A. Petosa, *Dielectric Resonator Antenna Handbook* (Artech House Antennas and Propagation Library), London, UK: Artech House, 2007.
- [21] B. Liu, S. Koziel, N. Ali, Sadea-ii: A generalized method for efficient global
495 optimization of antenna design, *Journal of Computational Design and Engineering*.